



Evaluation of PReVENT safety functions: methodology and first results Introducing eIMPACT and TRACE

Johan Scholliers, VTT



European Commission
Information Society and Media



- Project introduction
- Analysis of PReVENT results
- Proposal for assessment procedure of PReVENT functions
- EIMPACT and TRACE projects

- to **identify best practices** for the assessment of IP PReVENT safety functions.
- to define a **framework** for estimating the safety impact of preventive safety functions taking into account technical performance and human factors.
- to apply the framework to **estimate the potential safety impacts** of selected PReVENT applications.
- Make **recommendations for the future assessment** of preventive safety applications

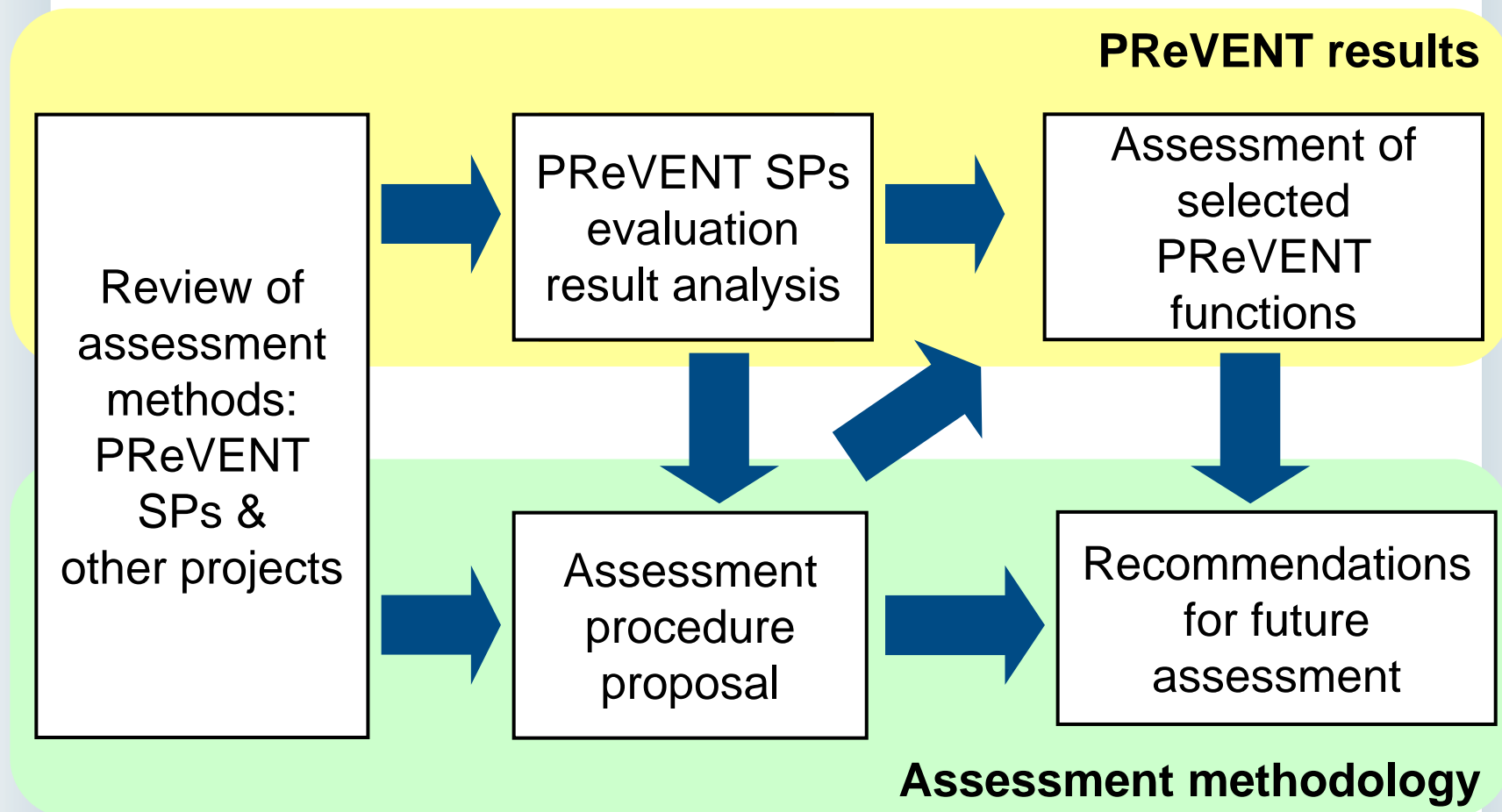

The three levels of safety



**Technical
performance
& reliability**

**Human Factors:
HMI &
driver behaviour**

Traffic safety

- Work in PReVAL organised according to 3 aspects of assessment:
- Technical performance assessment
- Human factors evaluation
- Safety potential estimation



Technical Performance Assessment Methods in PReVENT



- All validation plans follow CONVERGE guidelines
- More good practices than weaknesses, All validation plans lead to sound technical results
- However some differences and areas of improvement

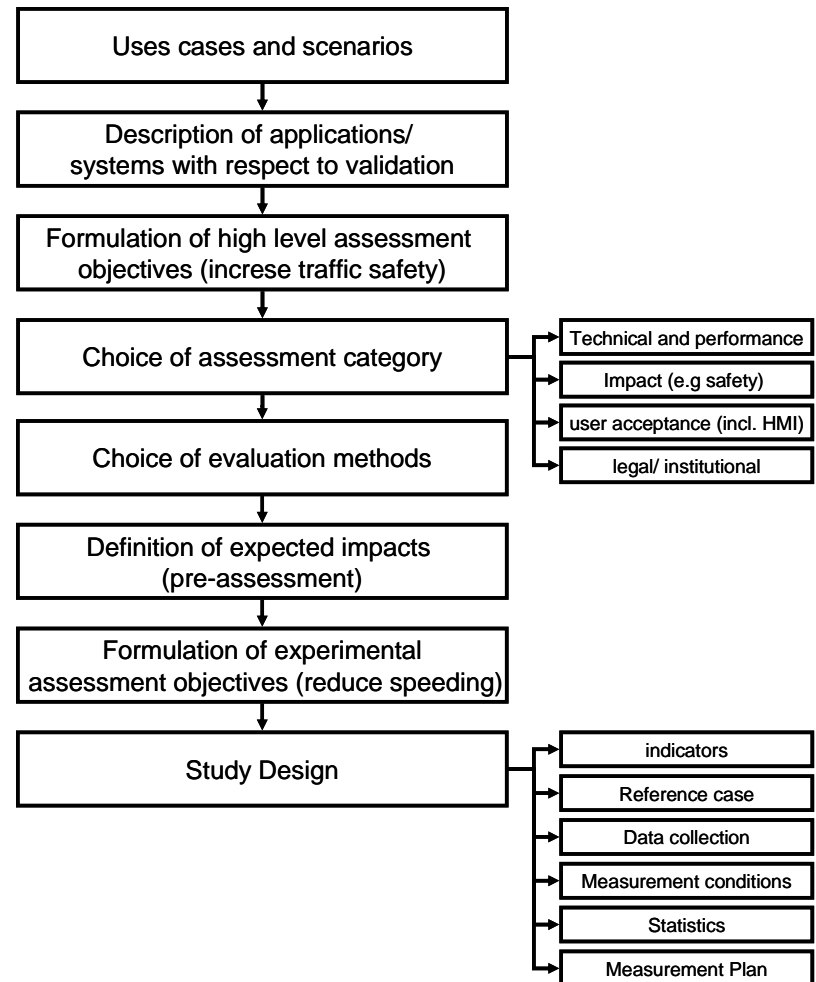

Evaluation issues to be addressed in new methodology



- Reference case:
 - How to define a suitable and reproducible test case? How to provide a reference to compare with the measured variables (e.g. temporal clock for TTC)
- Simulations, tracks tests or road tests :
 - How to choose them? Which of these types of tests should be carried out for subsystems and for the entire function evaluations?
- Indicator variables,
 - based on which the technical performance is assessed: which indicators are really concerned by a technical evaluation?



- No scientific established method for evaluating ADAS-HMI.
- Input from PReVENT subprojects rather limited
 - HMI not a main focus in PReVENT
- Key methodology developments in other projects: AIDE, RESPONSE3, INVENT

Overview of human factor evaluation results in PReVENT



PReVENT sub project	Status of the results	Results		
		Driver performance/behaviour	Acceptance	Usability
INTERSAFE	Finalized	+	+	++
LATERAL SAFE	Finalized	+	+	+
MAPS&ADAS	Preliminary	Not available	+	+
SAFELANE	Finalized	++	++	++
SASPENCE	Preliminary	+	++	+
WILLWARN	Finalized	++	+	+

+ : Indicates positive results, but with documented need for design improvements and/or further experiments.

++ Indicates positive results.

- Method based on behavioural effect approach
 - Telematic applications will have effects on accidents via change in travelling and driving behaviour of both users and non-users
 - Safety mechanisms:
 - direct modification of the driving task
 - indirect modification of user and non-user behaviour
 - modification of interaction between users and non-users
 - modifications of road user exposure, modal/route choice
 - accident consequences
 - Same methodology used by eIMPACT
 - Accident data provided by TRACE

Procedure of Safety Potential Assessment



- Definition of the systems in PReVENT SPs (applications, scenarios)
- Definition of relevant safety impact mechanisms and
 - Literature survey on the effects of the functions
- Quantitative estimate of the impacts
 - Preliminary estimate (by app.)
 - Safety analysis
 - Modifications of the assessment based on penetration
 - Overall quantitative estimate



- Starting point:
 - Best practices from PReVENT subprojects
 - Experiences from other projects, such as APROSYS, AIDE, INVENT
 - Impact analysis: behavioural effect approach

- New concepts :
 - situational control
 - Adapted V-shape design cycle : human factors & Technical new evaluation procedures

Situational control

the level of control jointly exerted by the driver and the vehicle in a specific driving situation.

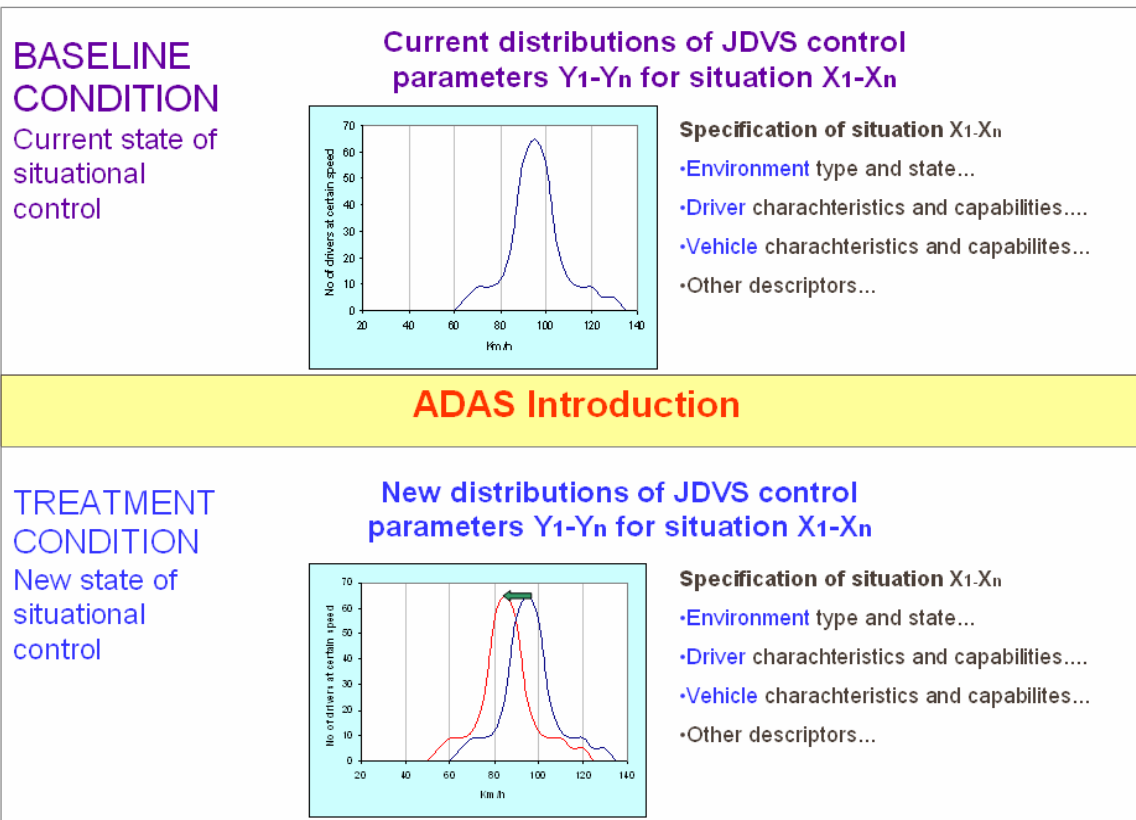

Relation between different evaluation aspects

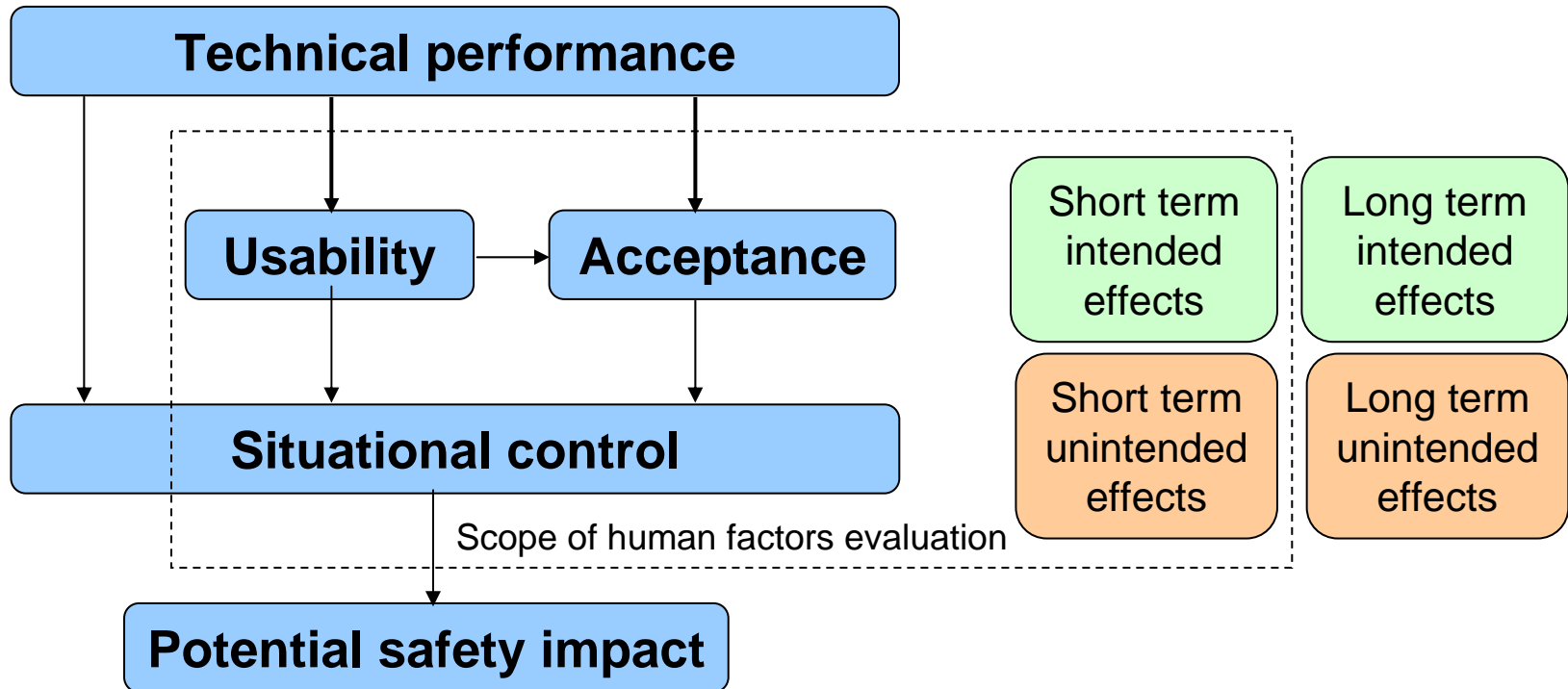

Adapted V-Shape Cycle

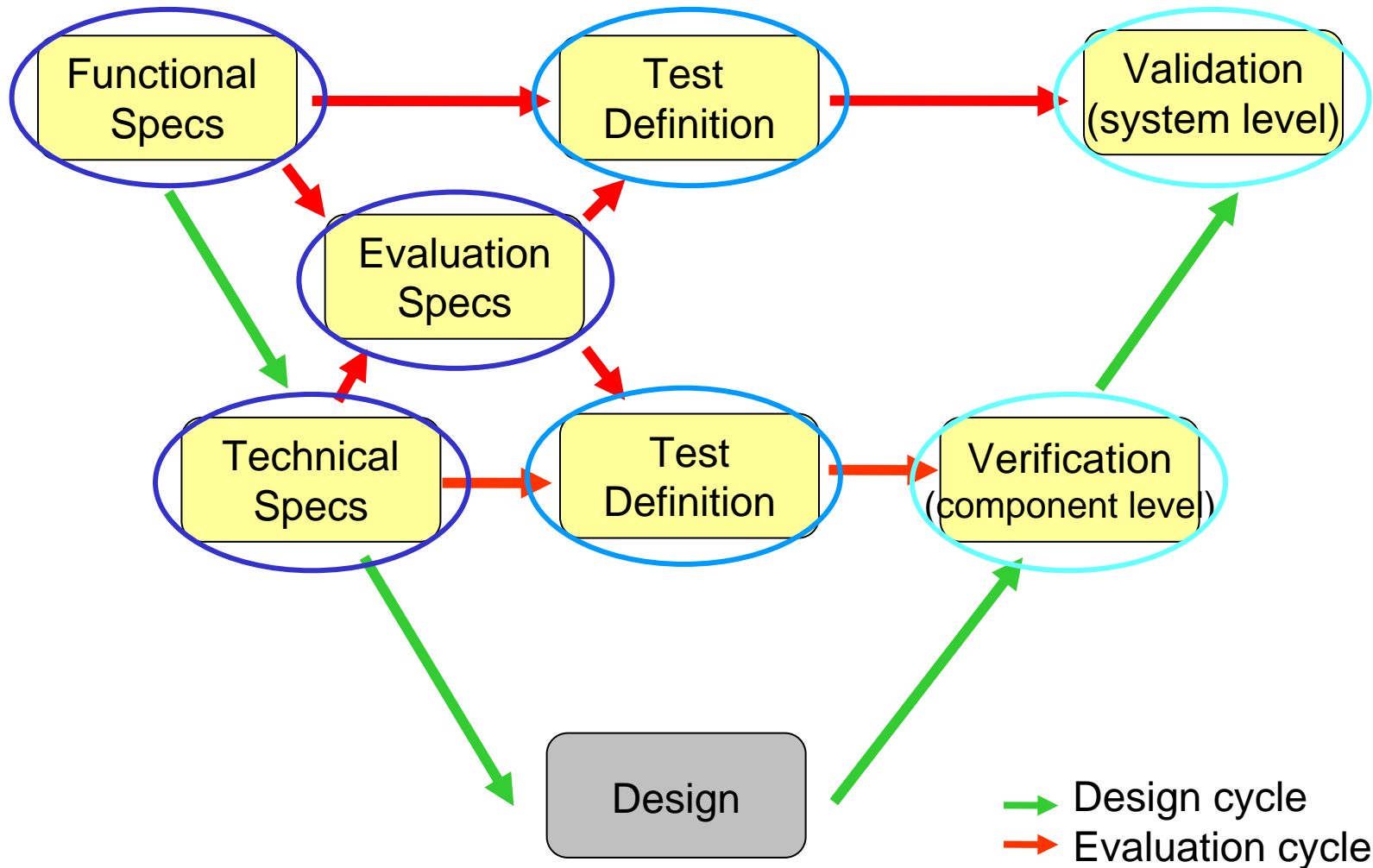

- Describe **functional requirements** at **system level**:
 - Application name and type
 - Type of vehicle the system is intended for
 - The (safety) functionality offered
 - Scenarios and use cases the system is designed for
- Describe **technical specifications** and system architecture at **component level**.
 - E.g. response time, range, sensor accuracy and operating conditions

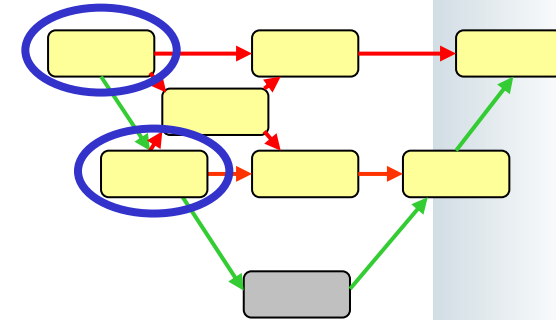

- Complete functional and technical specifications provided by the manufacturer such that:
 - The sub systems can be verified at component level
 - The system can be validated at functional level
- Functional evaluation specs
 - Classification (e.g. accident type, ADA type, target, road type)
 - Use cases (e.g. maneuver, operation conditions, relevance)
 - Objective & key indicators (e.g. TTC, impact speed)
- Technical evaluation specs
 - Minimal technical specs (e.g. range, FOV, accuracy, drop out rate, drop out duration)

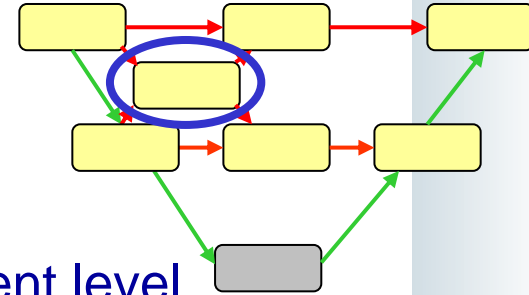

Technical Evaluation: test definition



- Define test plan to **verify** the components and **validate** the system
 - **Synthetic / real traffic Scenario**
 - Maneuvers
 - **(e.g. to test the sensor range)**
 - **(from accident statistics, positive and negative tests)**
 - Type of targets
 - Operational Conditions (weather/light)
 - **Tools**
 - Simulation
 - Component HiL-tests (VeHiL / Precrash)
 - Real world tests (Crash lab / Test track)
 - **Data Collection and Measurement plan**
 - Number of measurements
 - Parameters for sensitivity testing (e.g. parameters for maneuvers and operational conditions)

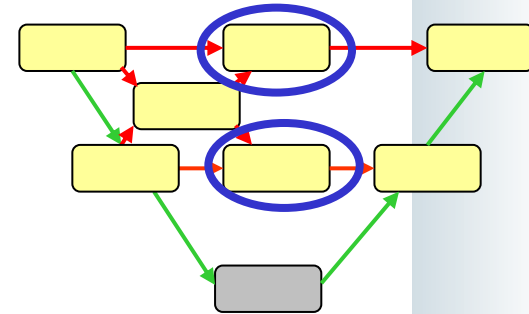

- Execute verification and validation tests according to test plan
- Analyze results and evaluate performance
- Report findings
- Give recommendations for adaptations of functional specifications or system design if necessary

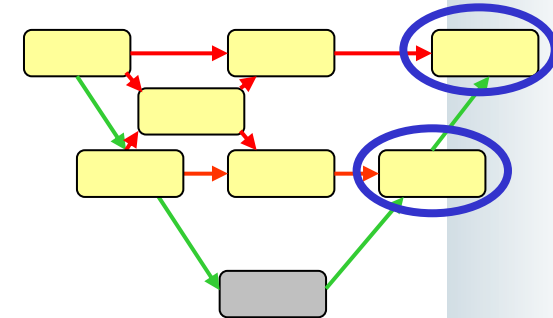

Human factor evaluation procedure

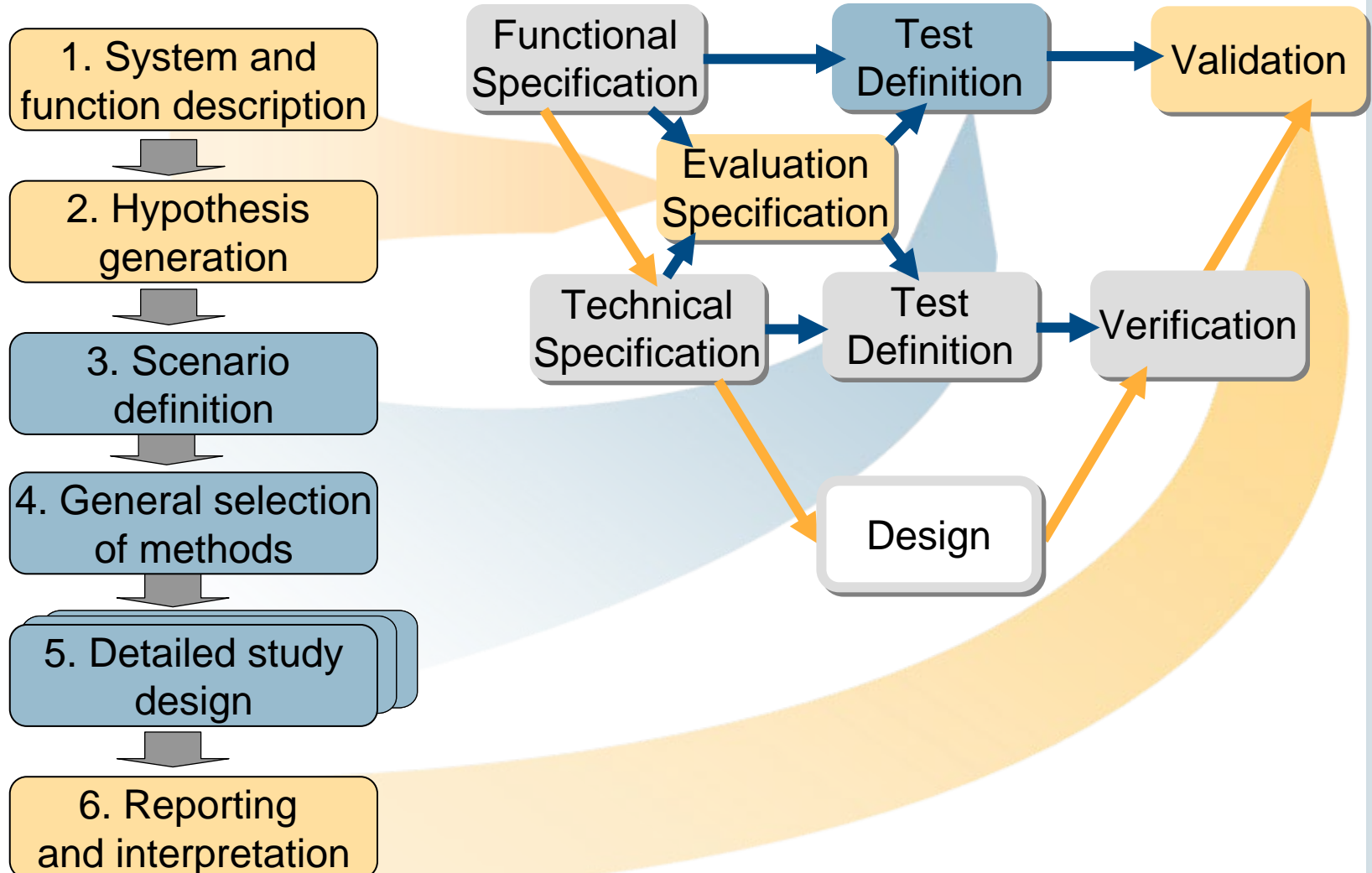

Complementarity of TRACE, eIMPACT and PReVAL



- **TRACE:**
 - Accident Research Needs for Evaluating the Effectiveness of Counter Measures Based on Technologies.
- **eIMPACT:**
 - Impact assessment of intelligent vehicle safety systems
- **PReVAL:**
 - Evaluation of PREVENT Safety functions



- **Socio-economic impact assessment of Integrated Vehicle Safety Systems (IVSS)**
 - identification of the most promising stand-alone and co-operative IVSS technologies
 - market penetration scenarios for IVSS
 - expected impacts on traffic safety and efficiency, detailed results for 2010 & 2020
- **Perspectives on the market introduction of IVSS**
 - integrating the input from the impact analysis, policy options and stakeholder roles
- **Geographical Scope: Europe → EU-25**

Overview of Work Packages

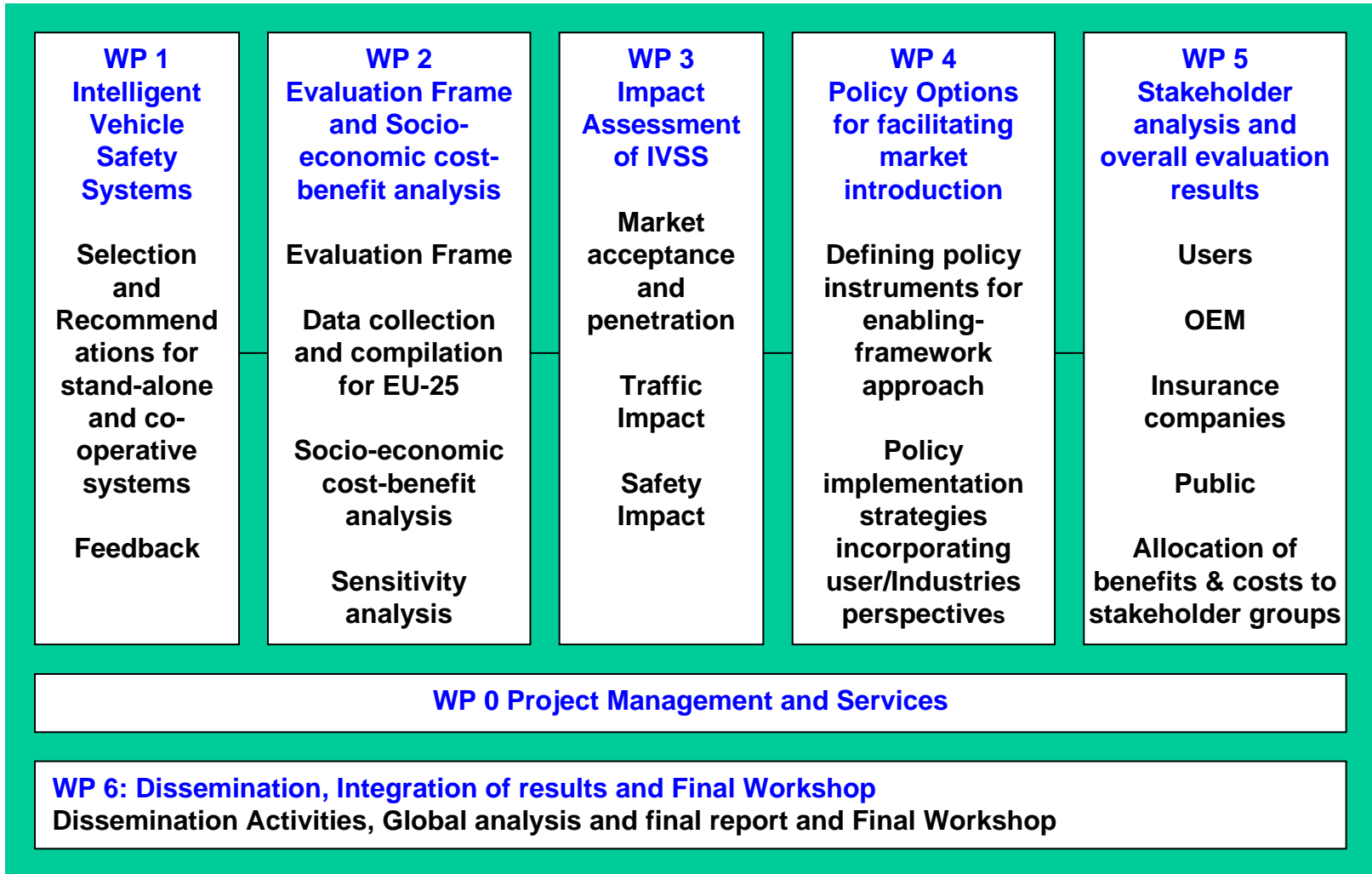

- **ESC based**
 - ACC/FSR; Emergency Braking; Collision Mitigation & Pre-Crash Protection of Vulnerable Road Users; ESC
- **'Driver on the road' / 'Road/line sides'**
 - Lane Keeping Support; Lateral & Rear Monitoring, Lane Change Aid and Lateral Collision Warning; Night Vision; Driver Drowsiness Monitoring and Warning
- **Co-operative systems**
 - Intersection Safety; Wireless Local Danger Warning; eCall; Speed Alert

- Traffic impact assessment
- Safety Impact Assessment
 - Qualitative analysis (mechanisms)
 - Quantitative analysis
 - Market penetration scenarios for 2010 and 2020
 - Accident data for different road types, accident types, circumstances
 - Changes (%) in number of fatalities, severe injuries and crashes in the 2 scenarios for 2010 and 2020
- Cost-benefit analysis
- Stakeholder Analysis

- eIMPACT analyses several PReVENT (based) systems
- PReVAL applies the same methodology for safety impact assessment as developed and used in eIMPACT
 - Similar approach means results can be compared
 - Results already available from eIMPACT (for the PReVENT systems) are used
- Several partners are involved in both eIMPACT and PReVAL
 - This ensures available expertise is well used

- PReVENT functions analysed by eIMPACT:
 - WILLWARN (Warning about stopped vehicle and Warning about reduced friction of visibility)
 - LATERALSAFE
 - INTERSAFE (Traffic light assistance and Right-of-way assistance)
 - SAFELANE
 - COMPOSE (Pre-crash/road-user protection)
- Functions in PReVAL selected so, that they do not overlap with eIMPACT



TRACE Objectives (Jan 2006 - June 2008)

- The **identification** and the **assessment** (in terms of saved lives and avoided accidents), among possible technology-based safety functions, of the **most promising solutions** that can assist the driver or any other road users in a normal road situation or in an emergency situation or, as a last resort, mitigate the violence of crashes and protect the vehicle occupants, the pedestrians, and the two-wheelers in case of a crash or a rollover.
- The **determination** and the continuous **up-dating of the aetiology**, i.e. causes, of road accidents (as well as the causes of injuries) and the assessment of whether the existing technologies or the technologies under current development address the real needs of the road users inferred from the accident and driver behaviour analyses.





TRACE Work Packages

- Evaluation of existing & promising safety devices **1**
- Update the knowledge about accident causation survey **2**

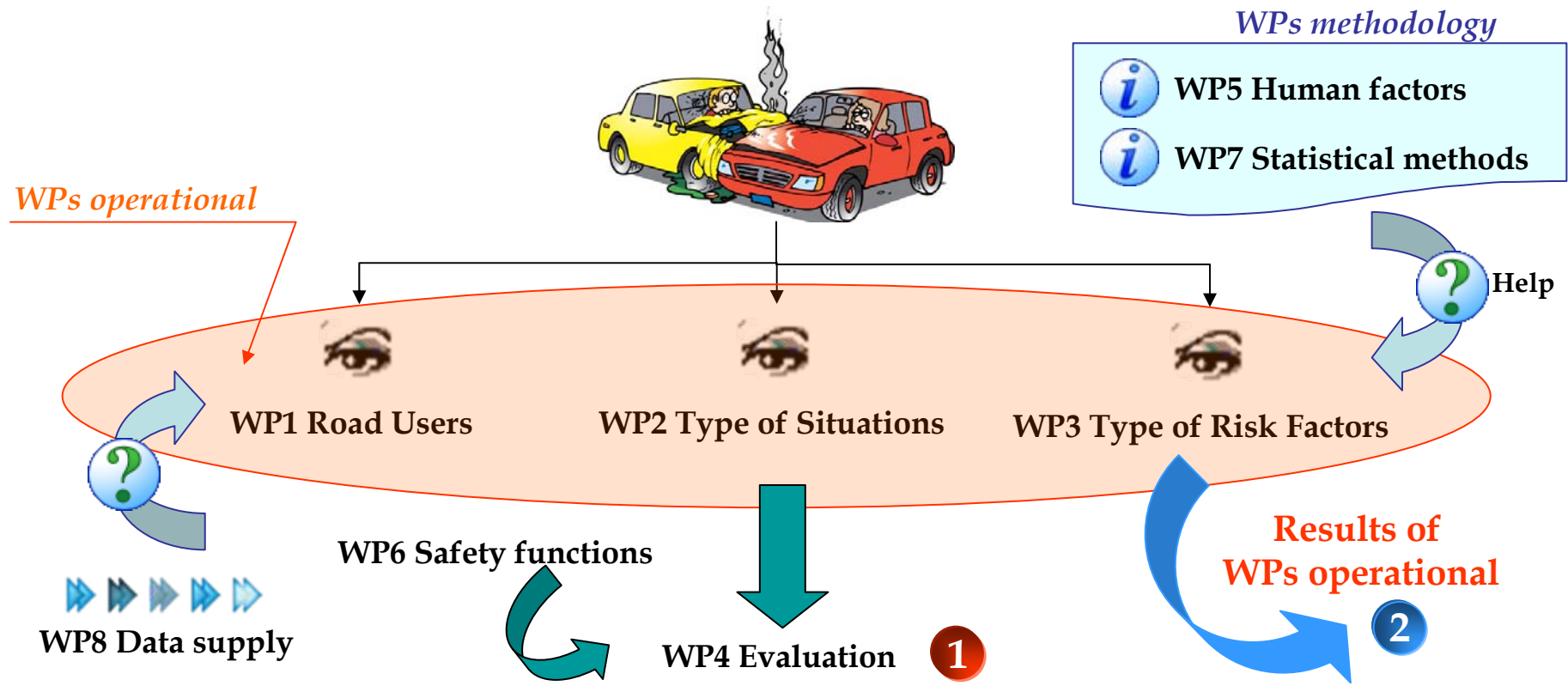



TRACE Conclusions

- Diagnosis of traffic safety problems at the European Level with 3 research angles (**Road Users** – **Types of Situations** – **Risk Factors**)
- Evaluation of the most promising technologies : ex ante and ex post
- Methodological improvements in Human factors Analysis and Statistical Analysis
- Rely on a set of various accident and exposure databases



Co-operation with TRACE and eIMPACT



- TRACE provides PReVAL and eIMPACT with accident data for impact analyses; discussion and selection of categories
- eIMPACT: same safety assessment framework and accident data, comparable results (without technical and HMI perspective)

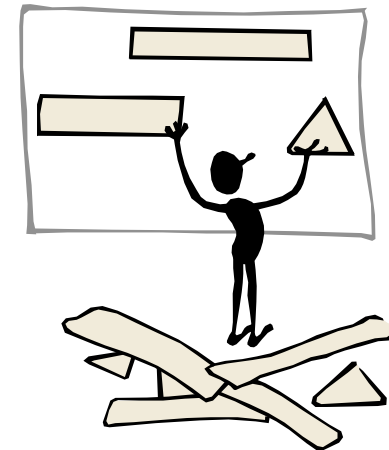

Contact information



- Please come to visit us at the PREVAL tent
- Final PReVAL workshop, 17.1.2008, Brussels
- For more information
 - PREVAL: Johan Scholliers, johan.scholliers@vtt.fi
 - eIMPACT: Kerry Malone, kerry.malone@tno.nl
 - TRACE: Yves Page, yves.page@lab-france.com

